

# A99B Series Temperature Sensors

*The A99B Series Temperature Sensors are passive PTC (Positive Temperature Coefficient) sensors. The A99B sensors are splashproof and are designed to measure temperature in a variety of refrigeration applications. Several accessories allow easy tailoring of the temperature sensor to various mounting configurations.*

*Applications include temperature sensing for freezers and coolers, as well as in defrost termination sensing, space and return air temperature sensing, and condenser fan cycling.*



**Figure 1: A99B Temperature Sensors**

<b>Features and Benefits</b>	
<input type="checkbox"/> <b>Variety of Lead Lengths</b>	Encompasses most application requirements and simplifies wiring sensors
<input type="checkbox"/> <b>Assortment of Mounting Hardware Available</b>	Provides configuration for many applications—customizable
<input type="checkbox"/> <b>Very Accurate Sensing Element</b>	Provides excellent performance in a wide variety of control applications
<input type="checkbox"/> <b>Stainless Steel Sensor Bulb</b>	Allows use in more applications than other types of bulbs; no corrosion

# Application Overview

**IMPORTANT:** All A99B Series Sensors are designed for use only with operating controls. Where an operating control failure would result in personal injury and/or loss of property, it is the responsibility of the installer to add devices (safety, limit controls) or systems (alarm, supervisory) that protect against, or warn of, control failure.

The A99B temperature sensor line offers an economical solution for a wide variety of temperature sensing needs in refrigeration and HVAC applications. Typical temperature sensing applications and environments include:

- freezers
- display cases
- walk-in coolers
- reach-in coolers
- defrost termination temperature sensing
- condenser fan cycling
- space and return air temperature sensing
- outdoor air sensing
- process cooling and heating

## Sensor Temperature Averaging

Multiple sensors may be wired in a series parallel arrangement to provide an average temperature reading in an area when one sensor cannot provide a representative temperature reading. This can be accomplished with 4, 9, 16, etc., ( $2^2$ ,  $3^2$ ,  $4^2$ , etc.) sensors.

In a series parallel arrangement, there must always be the same number of parallel-connected sensors as there are series connected sensors. In Figures 2-4, each parallel leg is represented as a column of sensors and each series leg as a row of sensors.

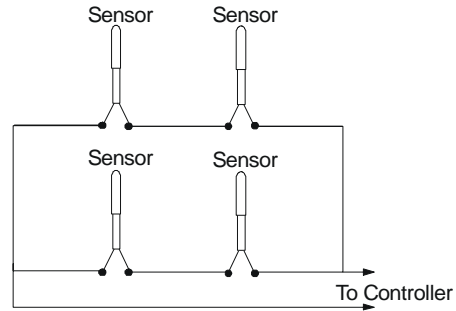

**Figure 2: 4-Sensor Averaging Wiring**

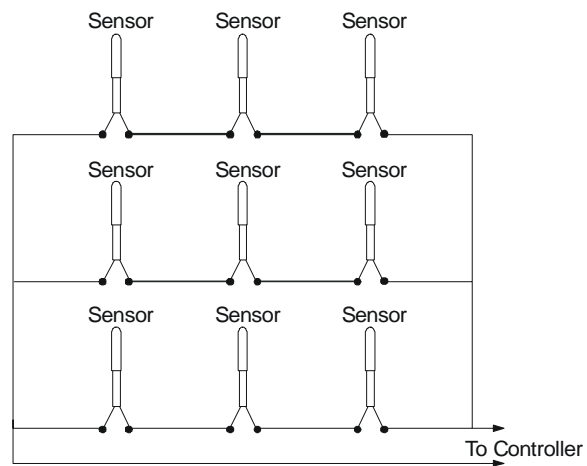

**Figure 3: 9-Sensor Averaging Wiring**

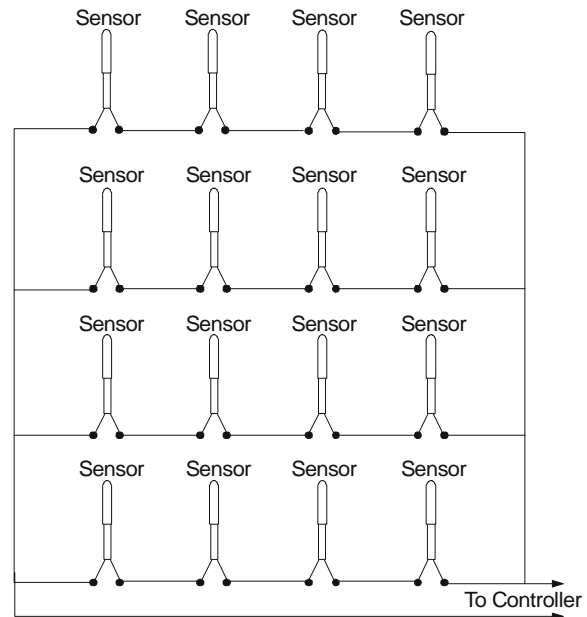

**Figure 4: 16-Sensor Averaging Wiring**

## Dimensions

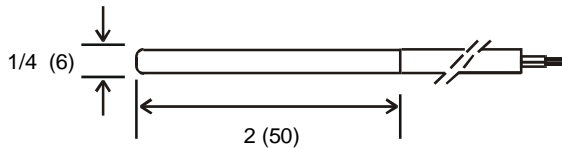

Figure 5: A99B Sensor, in. (mm)

## Accessories

A99B series accessories include the following:

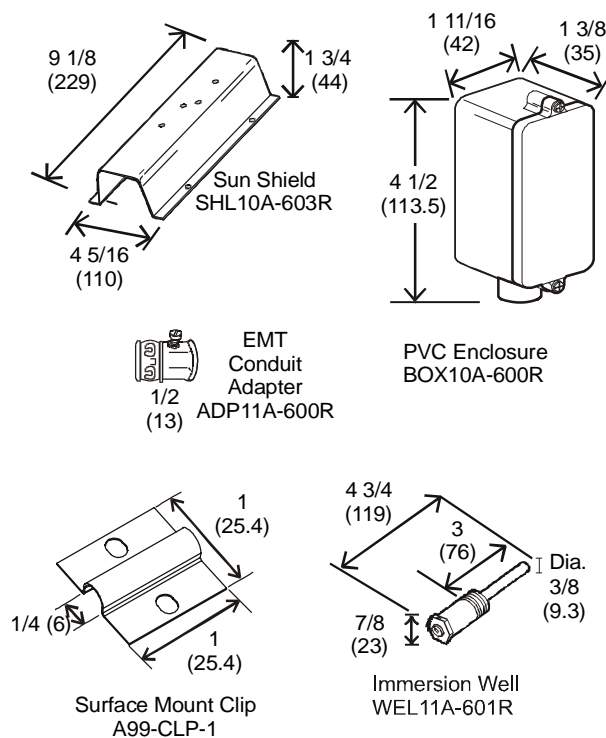

Figure 6: Available Accessories, in. (mm)

## Operation

The A99B sensor incorporates a PTC silicon sensing element whose resistance increases with an increase in temperature. The sensor has a reference resistance of 1035 ohms at 77°F (25°C). Each element is calibrated according to a standard graph, as shown in Table 2.

The A99B series sensors are typically used with Johnson Controls/PENN System 350™ controls, MR Defrost controls MS Multi-Stage controls, and A419 Electronic Temperature controls.

The A99B sensors can also be used with Johnson Controls System 27 NOVA; A255 fan speed control modules; and R78, DX-9100, XP-9102, XPA-4x1, and XPA-8x1 products.

## Mounting

### Mounting Considerations

The A99B sensor may be mounted in virtually any position. To ensure proper operation of the A99B Series sensors, observe the following guidelines:

- Mount sensors in areas where they are exposed to representative temperature conditions and sufficient air mixing. Avoid mounting the sensors where air stratification exists.
- Avoid areas subject to excessive mechanical vibration or electrical noise.
- For outdoor applications, avoid areas where the sensor will be exposed to direct sunlight because this causes the sensor to read a higher temperature. The north side of the building is preferred for outdoor sensors. If not possible, install a sun shield.
- Use a thermally conductive paste where appropriate to improve the thermal contact with the sensor.
- Do not subject silicon cable (A99BC) to any silicon-based fluids, as this will degrade the cable.

## Mounting Using an Immersion Well

1. Select the mounting location in the pipe line. A 1/2 in., 14 NPT, opening is required to properly install the immersion well (WEL11A-601R). The pipe's diameter must be greater than the length of the well probe.
2. Insert an appropriate amount of thermally conductive paste in the well.
3. Install the immersion well. Tighten hex nut securely using a wrench.

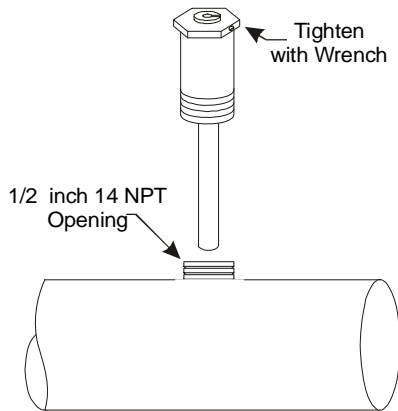

**Figure 7: Installing the Immersion Well**

4. Using a straight slot screwdriver, loosen the set screw at top of the immersion well.
5. Thread the spring, then the bushing, onto the sensor lead.

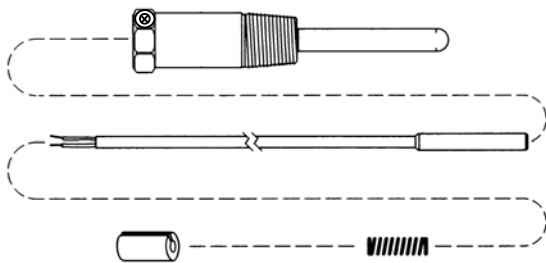

**Figure 8: Insert Sensor, Spring, and Bushing**

6. Insert sensor, spring, and bushing into well, so that at least one-half of the bushing is inserted into the well, as shown in Figure 8 (bushing will compress spring).
7. Tighten the set screw against the bushing.

## Mounting with a PVC Enclosure

The PVC enclosure can be mounted in a variety of ways. See Figure 6 for mounting dimensions. When mounting the PVC enclosure, refer to the *Mounting Considerations* section, as well as the following:

- To minimize false readings caused by air movement through the conduit hole, seal that part of the enclosure after the sensor has been inserted.
- If a conduit connection is required, snap the conduit adapter into the bottom opening of the enclosure and tighten the adapter's set screw.

1. Loosen the two PVC enclosure screws and remove the front plate.

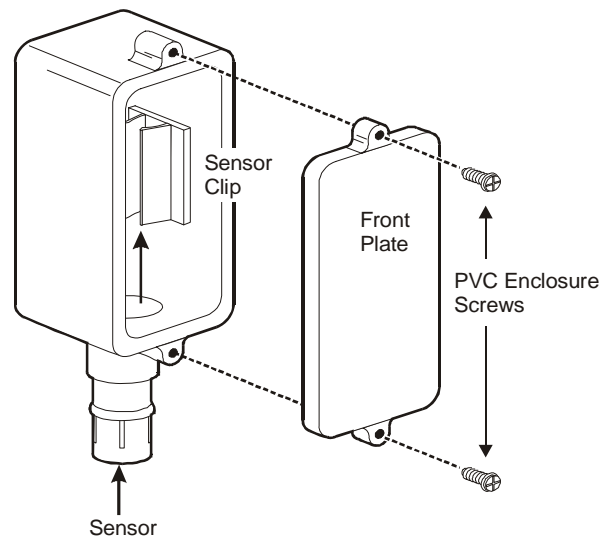

**Figure 9: PVC Enclosure**

2. Thread the sensor through the bottom opening and snap the sensor in the sensor clip inside the PVC enclosure.
3. Replace the front plate on the PVC enclosure and firmly tighten the screws.

# Wiring



**WARNING: Shock Hazard.** Disconnect all power to the controller that the sensor is connected to before wiring or servicing.

For wiring, follow the instructions below:

- Make sure all wiring conforms to the National Electric Code and local regulations.
- Run high and low voltage wiring in separate conduits. For applications in critical industrial environments, use a sensor with a shielded cable (A99BA).
- If wire is added to the sensor leads, additional resistance may affect the sensor reading. Longer wires increase resistance, which causes a shift in the sensor temperature reading.

Note: At the wire lengths listed in Table 1, the error in the sensed temperature is less than 1°F (0.5°C).

**Table 1: Maximum Sensor Wire Lengths (for less than 1°F error)**

Wire Gauge	Wire Length	
	Feet	Meters
14 AWG	800	244
16 AWG	500	152
18 AWG	310	94
20 AWG	200	61
22 AWG	124	38

- Shielded Cable Models (A99BA) Only: For all controls, including the Johnson Controls/PENN System 350, MR, MS, and A419, connect the sensor cable shield to the controller per the controller's instructions.

# Checkout Procedure

Before applying power, make sure installation and wiring connections are according to job specifications. After necessary adjustments and electrical connections have been made, operate the system and observe at least three complete cycles before leaving the installation.

# Troubleshooting

Check the sensor for proper resistance:

1. Disconnect the sensor from the control.
2. Take a temperature reading at the sensor location. Be sure to let the thermometer stabilize before taking a reading.
3. Use the temperature reading from Step 2 to determine the expected sensor resistance from Table 2.
4. Using an ohmmeter, measure the actual resistance across the two sensor leads.
5. Compare the expected resistance to the actual resistance.
6. If the sensor's actual resistance deviates substantially from the expected resistance found in Table 2, replace the sensor.

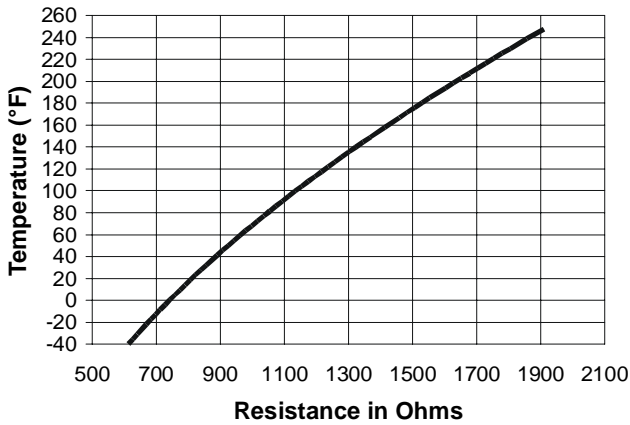

**Figure 10: Resistance Scale for Fahrenheit Temperatures**

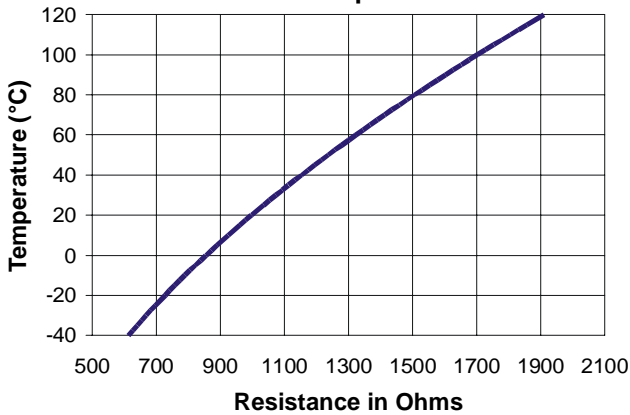
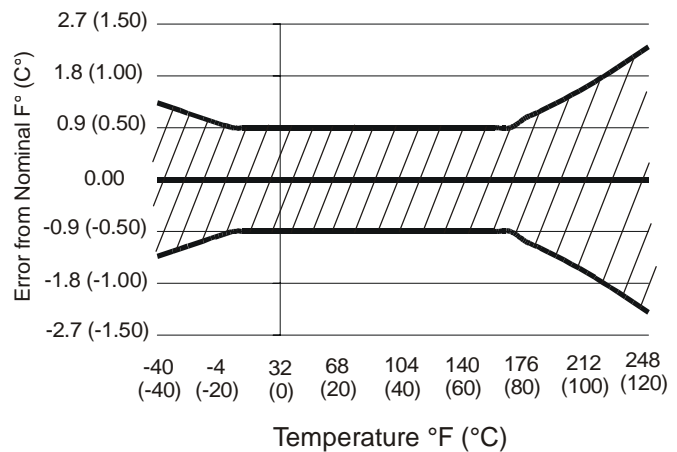

**Figure 11: Resistance Scale for Celsius Temperatures**

**Table 2: Resistance vs. Temperature**

°F (°C)	Resistance in Ohms	°F (°C)	Resistance in Ohms
-40 (-40)	613	113 (45)	1195
-31 (-35)	640	122 (50)	1237
-22 (-30)	668	131 (55)	1279
-13 (-25)	697	140 (60)	1323
-4 (-20)	727	149 (65)	1368
5 (-15)	758	158 (70)	1413
14 (-10)	789	167 (75)	1459
23 (-5)	822	176 (80)	1506
32 (0)	855	185 (85)	1554
41 (5)	889	194 (90)	1602
50 (10)	924	203 (95)	1652
59 (15)	960	212 (100)	1702
68 (20)	997	221 (105)	1753
77 (25)	1035	230 (110)	1804
86 (30)	1074	239 (115)	1856
95 (35)	1113	248 (120)	1908
104 (40)	1153		

Sensor accuracy is within 0.9°F (0.5°C) between 5 and 167°F (-15 and 75°C). Tolerance increases at temperatures outside this range, as shown in Figure 12.



**Figure 12: Sensor Accuracy**

## Repairs and Replacement

Field repairs or calibration must not be made. For replacement sensors, contact your nearest Johnson Controls/PENN representative.

When contacting the supplier, state the model number of the sensor. The sensor model is printed on the yellow label wrapped around the sensor cable.

## Ordering Information

**Table 3: Sensors**

Product Code Number	Description
<b>A99BA-200C</b>	PTC Silicon Sensor with Shielded Cable; Cable length 6-1/2 ft (2 m); Range: -40 to 212°F (-40 to 100°C)
<b>A99BB-25C</b>	PTC Silicon Sensor with PVC Cable; Cable length 9-3/4 in. (0.25 m); Range: -40 to 212°F (-40 to 100°C)
<b>A99BB-200C</b>	PTC Silicon Sensor with PVC Cable; Cable length 6-1/2 ft (2 m); Range: -40 to 212°F (-40 to 100°C)
<b>A99BB-200D</b>	PTC Silicon Sensor with PVC Cable Bulk Pack; contains 100 A99BB-200 sensors. Individual sensor cable length 6-1/2 ft (2 m); Range: -40 to 212°F (-40 to 100°C)
<b>A99BB-300C</b>	PTC Silicon Sensor with PVC Cable; Cable length 9-3/4 ft (3 m); Range: -40 to 212°F (-40 to 100°C)
<b>A99BB-500C</b>	PTC Silicon Sensor with PVC Cable; Cable length 16-3/8 ft (5 m); Range: -40 to 212°F (-40 to 100°C)
<b>A99BB-600C</b>	PTC Silicon Sensor with PVC Cable; Cable length 19-1/2 ft (6 m); Range: -40 to 212°F (-40 to 100°C)
<b>A99BC-25C</b>	PTC Silicon Sensor with High Temperature Silicon Cable Cable length 9-3/4 in. (0.25 m); Range: -40 to 248°F (-40 to 120°C)
<b>A99BC-300C</b>	PTC Silicon Sensor with High Temperature Silicon Cable Cable length 9-3/4 ft (3 m); Range: -40 to 248°F (-40 to 120°C)
<b>A99BC-1500C</b>	PTC Silicon Sensor with High Temperature Silicon Cable Cable length 49 ft (15 m); Range: -40 to 248°F (-40 to 120°C)

**Table 4: Accessories (See Figure 6 for illustration of accessories.)**

Product Code Number	Description
<b>A99-CLP-1</b>	Surface Mounting Clip for the A99B Temperature Sensor
<b>ADP11A-600R</b>	1/2 in. diameter EMT Conduit Adapter (box of 10) for use with BOX10A-600R
<b>BOX10A-600R</b>	PVC Enclosure
<b>SHL10A-603R</b>	Sun Shield
<b>WEL11A-601R</b>	Immersion Well

# Specifications

<b>Product</b>	A99B Series Silicon Temperature Sensors
<b>Sensing Range</b>	Model A99BA and A99BB: -40 to 212°F (-40 to 100°C) Model A99BC: -40 to 248°F (-40 to 120°C)
<b>Reference Resistance</b>	1035 ohms at 77°F (25°C)
<b>Accuracy</b>	0.9°F (0.5°C) between 5 and 167°F (-15 and 75°C). See Figure 12 for accuracy outside of this range.
<b>Sensor Construction</b>	Probe: Stainless Steel
<b>Sensor Lead Wire Insulation</b>	Model A99BA: Shielded PVC Cable Model A99BB: PVC Cable Model A99BC: High Temperature Silicon Cable
<b>Lead Wire Gauge</b>	22 AWG
<b>Ambient Operating Conditions</b>	Model A99BA and A99BB: -40 to 212°F (-40 to 100°C); 0 to 100% RH, Condensing Model A99BC: -40 to 248°F (-40 to 120°C); 0 to 100% RH, Condensing
<b>Ambient Storage Conditions</b>	Model A99BA and A99BB: -40 to 221°F (-40 to 105°C); 0 to 100% RH, Condensing Model A99BC: -40 to 266°F (-40 to 130°C); 0 to 100% RH, Condensing
<b>Shipping Weight</b>	1.4 oz (41 g) for 6 1/2 ft (2 m) sensor
<b>Accessories</b>	See Table 4.

The performance specifications are nominal and conform to acceptable industry standards. For application at conditions beyond these specifications, consult Johnson Controls/Penn Application Engineering at (414) 274-5535. Johnson Controls, Inc. shall not be liable for damages resulting from misapplication or misuse of its products.



**Controls Group**  
507 E. Michigan Street  
P.O. Box 423  
Milwaukee, WI 53201

www.johnsoncontrols.com  
Printed in U.S.A.